

# LMS-183CX Lab Brick® Signal Generator

6 GHz – 18 GHz Frequency | Chirp Rates to 50 MHz/μs | 100 Hz Step Size

## Features/Benefits

- Extremely Fast Switching
- Includes GUI, Windows and Linux SDK, LabVIEW driver
- Chirp modulation and frequency sweep rates up to 50 MHz/μs
- Operate multiple devices directly from a PC or self powered hub
- Excellent harmonic rejection
- Internal/external pulse modulation
- Easily portable USB powered device
- Sized to fit into a single rack unit for ATE applications



## Applications

- Low Cost Test Equipment for RADAR Receiver Systems
- Portable LO Source
- Engineering/Production Test Labs
- Automated Test Equipment (ATE)

The Lab Brick LMS series of Signal Generators bring affordability, functionality, reliability and simplicity to the microwave test bench. The LMS products range from 0.5 MHz to 20 GHz with 100 Hz step size, 0.5 dB power control steps and linear frequency sweep capability. Lab Bricks use a native USB HID interface to avoid the difficulties inherent in using older serial or IEEE-488 interfaces implemented over USB. As a result, Lab Brick users can get to work faster without having to install kernel level drivers, and Lab Brick devices can be easily used on any system that supports USB HID devices, including low cost embedded computers using Linux or similar operating systems.

The LMS-183CX is an affordable Signal Generator with fast internally or externally triggered chirp modulation. The LMS-183CX provides calibrated power control from 6 to 18 GHz with a 100 Hz frequency setting resolution. The signal generator is easily programmable for fixed frequency operation, unidirectional or bidirectional frequency sweep, pulse and chirp modulation directly from the included Graphical User Interface (GUI). Alternatively, for users wishing to develop their own interface, Vaunix supplies LabVIEW drivers, Windows API DLL files, Linux drivers, Python examples and much more.

# LMS-183CX Specifications

Parameter	Test Conditions	Min	Typ	Max
Frequency	Range (GHz)	6		18
	Step Size (Hz)	100		
	Accuracy (ppm)			+/-2
	Switching ( $\mu$ s)		20	
Phase Noise (dBc/Hz) 10, 100, 1000, 10000 kHz	@6 GHz		-83/-83/-103/-130	
	@8 GHz		-82/-82/-97/-130	
	@12 GHz		-79/-79/-95/-130	
	@18 GHz		-75/-75/-92/-130	
Output Power	Maximum (dBm)	9.25	10	10.75
	Resolution (dB)		0.5	
	Range (dB) from 6-13 GHz		80	
	Range (dB) from 13-18 GHz		65	
	Accuracy (dB)		+/-1.0	+/-2.5
Spurious	Inband (dBc)		-55	
	Harmonics (dBc)		-35	
VSWR			1.5:1	
Reference (Int/Ext)	Frequency (MHz)		10	
	Input Level (Vpp)	0.5	1	3
	Output Level (Vpp)	0.5	1	3
Chirp Modulation	Band 1 (GHz)	6		11
	Band 2 (GHz)	11		18
	Chirp Rate (MHz/us)			50
	Chirp Duration ( $\mu$ s)	0.8		
	Chirp Repetition Interval ( $\mu$ s)	10.8		
	Edge Trigger input (Vpp) <sup>1</sup>	3		5
Phase Continuous Linear Frequency Sweep	Band 1 (GHz)	6		11
	Band 2 (GHz)	11		18
	Sweep Time (sec)	0.001		1000
	Edge Trigger input (Vpp)	3		5
Pulse Modulation (Int/Ext)	Pulse Depth (dB)	60	70	
	Pulse Width (ns)	100		
	Pulse Repetition Interval (ns)	200		
	Resolution (ns)	100		
	Trigger in/out (Vpp)	3		5

<sup>1</sup> Chirp Trigger Output is available on the Pulse Trigger port

## LMS-183CX Specifications

---

<i>Parameter</i>	<i>Test Conditions/Notes</i>	
<b>Power Requirements</b>	From the USB connection	+5 VDC 650 mA typical
<b>Environmental</b>	Operating Temperature	0 °C to +50 °C
	Relative Humidity (non-condensing)	<95%
<b>Physical Connections</b>	Power and Control	USB Type B – female
	RF Connector	SMA – female
	10 MHz Reference	BNC - female
	Pulse Modulation	BNC - female
	Frequency Sweep Trigger	BNC - female
<b>Optional Features</b>	None	
<b>Mechanical</b>	Size	4.9 x 3.14 x 1.59 inches 124 x 80 x 40 millimeters
	Weight	1.0 pounds 0.45 kilograms

# LMS-183CX Performance Plots

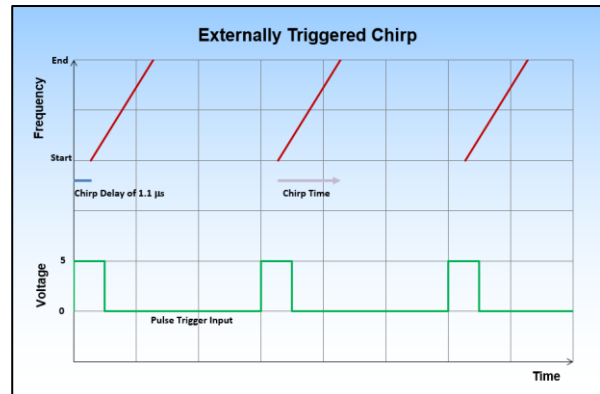
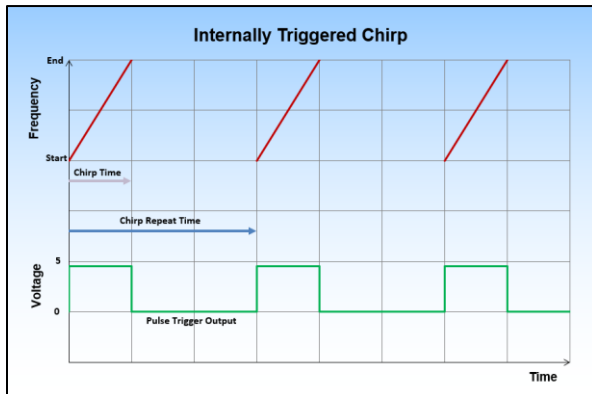
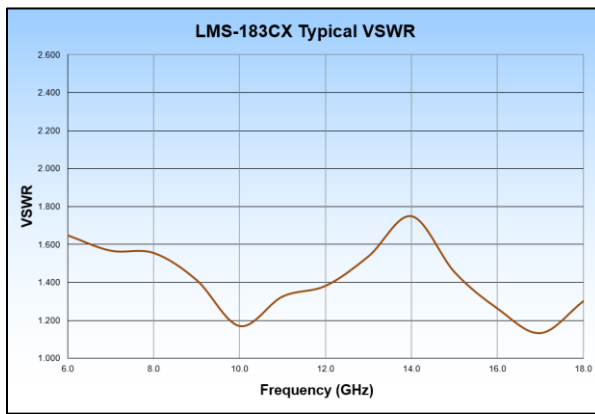
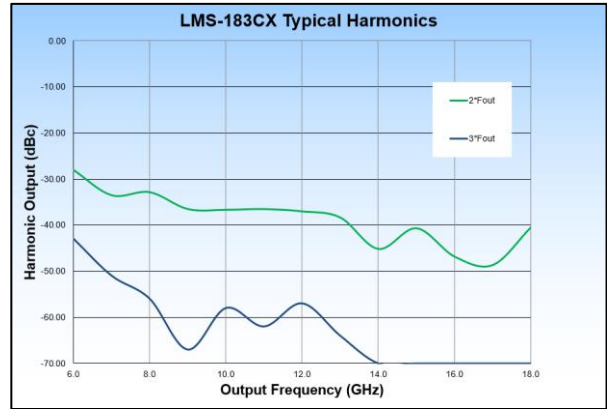
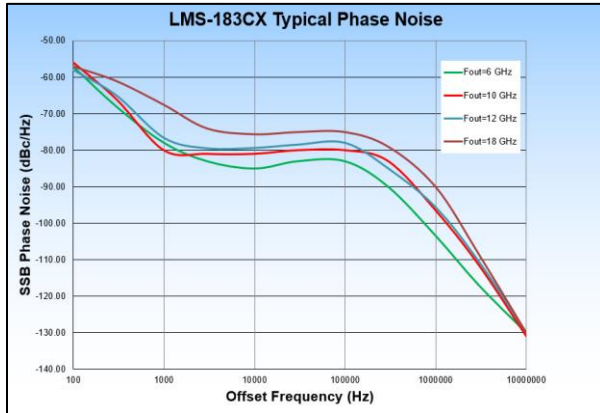

# LMS-183 Mechanical Outline

## Standard Unit

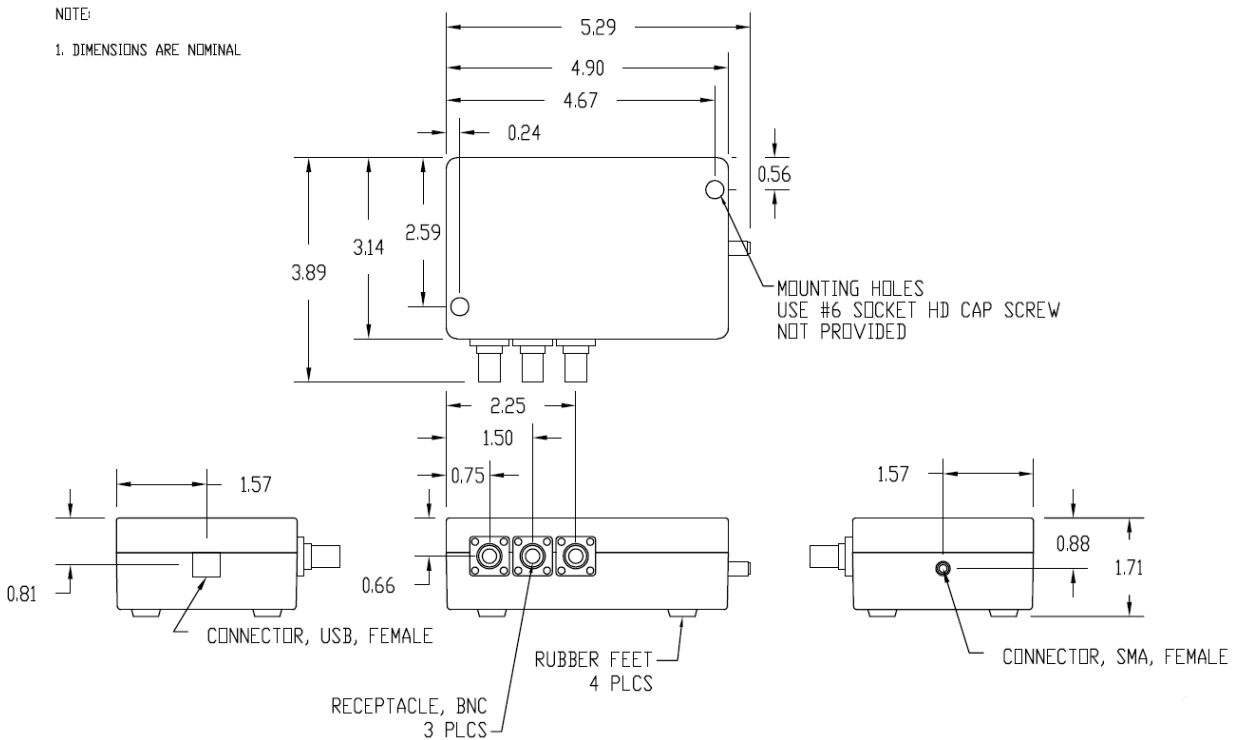

## LDA-183CX Software Interface

